

Generating hyperchaotic Lü attractor via state feedback control

Aimin Chen^a, Junan Lu^a, Jinhu Lü^{b,*}, Simin Yu^c

^aCollege of Mathematics and Statistics, Wuhan University, Wuhan 430072, China

^bKey Laboratory of Systems and Control, Institute of Systems Science, Academy of Mathematics and Systems Science, Chinese Academy of Sciences, Beijing 100080, China

^cCollege of Automation, Guangdong University of Technology, Guangzhou 510090, China

Received 18 May 2005; received in revised form 27 August 2005

Available online 10 October 2005

Abstract

This paper constructs a new hyperchaotic system based on Lü system by using a state feedback controller. The detailed dynamical behaviors of this hyperchaotic system are further investigated, including Lyapunov exponents spectrum, bifurcation, and Poincaré mapping. Moreover, a novel circuit diagram is designed for verifying the hyperchaotic behaviors and some experimental observations are also given.

© 2005 Elsevier B.V. All rights reserved.

Keywords: Hyperchaos; Lyapunov exponent; Bifurcation; Periodic orbit; Circuit realization

1. Introduction

Over the past two decades, chaos has been found to be very useful and has great potential in many engineering-oriented applied fields such as in encryption and communications, power systems protection, liquid mixing, information sciences, and so on [1–3].

In a broad sense, chaos control can be classified into two categories: one is to suppress the chaotic dynamical behavior when it is harmful, and the other is to generate or enhance chaos when it is desirable—known as chaotification or anticontrol of chaos [1]. Today, chaotification is a very attractive theoretical subject, which however is quite challenging technically [4–11].

In 1963, Lorenz discovered the first classical chaotic system. In 1999, Chen and Ueta found the dual system of Lorenz system via chaotification approach, in the sense of Lorenz system with $a_{12}a_{21} > 0$ and Chen system with $a_{12}a_{21} < 0$ from the definition of Vaněček and Čelikovský [1], where a_{12} and a_{21} are the corresponding elements in the linear part matrix $A = (a_{ij})_{3 \times 3}$ of the system. In 2002, Lü and Chen discovered the critical chaotic system between the Lorenz and Chen systems [4,5], satisfying $a_{12}a_{21} = 0$. In 2002, Lü et al. unified the above three chaotic systems into a new chaotic system—unified chaotic system [6].

Hyperchaotic system is usually defined as a chaotic system with more than one positive Lyapunov exponent. As we know now, there are many hyperchaotic systems discovered in the high-dimensional social and economical systems [12–15]. Typical examples are four-dimensional (4D) hyperchaotic Rössler system [12], 4D

*Corresponding author.

E-mail address: jhlu@iss.ac.cn (J. Lü).

hyperchaotic Lorenz–Haken system [13], 4D hyperchaotic Chua's circuit [14], and 4D hyperchaotic Chen system [15]. Since hyperchaotic system has the characteristics of high capacity, high security and high efficiency, it has broadly applied potential in nonlinear circuits, secure communications, lasers, neural networks, biological systems, and so on.

This paper introduced a new hyperchaotic system based on Lü system by adding a state feedback controller. The rest of this paper is organized as follows. A new hyperchaotic system is proposed in Section 2. Section 3 further investigates the dynamical behaviors of this hyperchaotic system. A novel circuit diagram is constructed for physically realizing this hyperchaotic system in Section 4. Conclusions are finally drawn in Section 5.

2. Hyperchaotic Lü system

The Lü system is described by [4,5]

$$\begin{cases} \dot{x} = a(y - x), \\ \dot{y} = -xz + cy, \\ \dot{z} = xy - bz, \end{cases} \quad (1)$$

where a, b, c are real constants. When $a = 36, b = 3, c = 20$, Lü system has a typically critical chaotic attractor with Lyapunov exponents $\lambda_1 = 1.5046, \lambda_2 = 0, \lambda_3 = -22.5044$ and Lyapunov dimension $d_L = 2.0669$ [1].

It is well known that, to generate hyperchaos from the dissipatively autonomously polynomial systems, the state equation must satisfy the following two basic conditions:

- (1) The dimension of the state equation is at least 4 and the order of the state equation is at least 2.
- (2) The system has at least two positive Lyapunov exponents satisfying that the sum of all Lyapunov exponents is less than zero.

Based on Lü system and above two basic conditions, we construct a simple 4D hyperchaotic system by introducing a state feedback controller as follows:

$$\begin{cases} \dot{x} = a(y - x) + u, \\ \dot{y} = -xz + cy, \\ \dot{z} = xy - bz, \\ \dot{u} = xz + du, \end{cases} \quad (2)$$

where a, b, c are the constants of Lü system and d is a control parameter. Hereafter, for simplification, system (2) is called hyperchaotic Lü system.

3. Dynamical behaviors of hyperchaotic Lü system

This section further investigates the dynamical behaviors of hyperchaotic Lü system, including equilibrium points, bifurcation, and Poincaré mapping.

3.1. Equilibrium points and phase portrait

If $c - ad \neq 0$, system (2) has three equilibrium points:

$$\begin{aligned} &O(0, 0, 0, 0), \\ &P_1 \left(\sqrt{bc}, -\frac{ad\sqrt{bc}}{c - ad}, -\frac{acd}{c - ad}, \frac{ac\sqrt{bc}}{c - ad} \right), \\ &P_2 \left(-\sqrt{bc}, \frac{ad\sqrt{bc}}{c - ad}, -\frac{acd}{c - ad}, -\frac{ac\sqrt{bc}}{c - ad} \right). \end{aligned}$$

Obviously, P_1 and P_2 are symmetric about x, y, u -axis for any parameters a, b, c, d . When $a = 36, b = 3, c = 20, d = 1.3$, the eigenvalues of equilibrium point O are $20, 1.3, -3, -36$. Then O is a two-dimensional unstable saddle point. Similarly, the eigenvalues of equilibrium points P_1, P_2 are $0.7356, -14.1698, -2.1329 \pm 23.1139i$ and it is a one-dimensional unstable saddle point.

Assume that the Lyapunov exponents of system (2) are λ_i for $i = 1, 2, 3, 4$ satisfying $\lambda_1 > \lambda_2 > \lambda_3 > \lambda_4$. Then the dynamical behaviors of system (2) can be classified as follows:

- (1) For $\lambda_1 > \lambda_2 > 0, \lambda_3 = 0, \lambda_4 < 0$ and $\lambda_1 + \lambda_2 + \lambda_4 < 0$, system (2) is hyperchaos.
- (2) For $\lambda_1 > 0, \lambda_2 = 0, \lambda_4 < \lambda_3 < 0$ and $\lambda_1 + \lambda_3 + \lambda_4 < 0$, system (2) is chaos.
- (3) For $\lambda_1 = 0, \lambda_4 < \lambda_3 < \lambda_2 < 0$, system (2) is a periodic orbit.
- (4) For $\lambda_4 < \lambda_3 < \lambda_2 < \lambda_1 < 0$, system (2) is an equilibrium point.

Moreover, the Lyapunov dimension d_L of system (2) satisfies $2 < d_L < 3$ for chaos case and $3 < d_L < 4$ for hyperchaos case. Our numerical analysis shows that the dynamical behaviors of system (2) switch among chaotic state, periodic orbit, and hyperchaotic state with the increasing of parameter d . Fig. 1 shows the Lyapunov exponents spectrum of system (2) with the increasing of parameter d , where $a = 36, b = 3, c = 20$.

When $a = 36, b = 3, c = 20$, we have

- (1) System (2) has a periodic orbit for $-1.03 \leq d \leq -0.46$ as shown in Fig. 2(a).
- (2) System (2) has a chaotic attractor for $-0.46 < d \leq -0.35$ as shown in Fig. 2(b).
- (3) System (2) has a hyperchaotic attractor for $-0.35 < d \leq 1.30$ as shown in Fig. 2(c).

Fig. 3 shows various plane projections of hyperchaotic attractor for $a = 36, b = 3, c = 20, d = 1.3$.

3.2. Bifurcation diagram

Fig. 4 shows the bifurcation diagram of system (2) in the $x-d$ plane. It is noticed that this diagram covers the whole real parameter region of d .

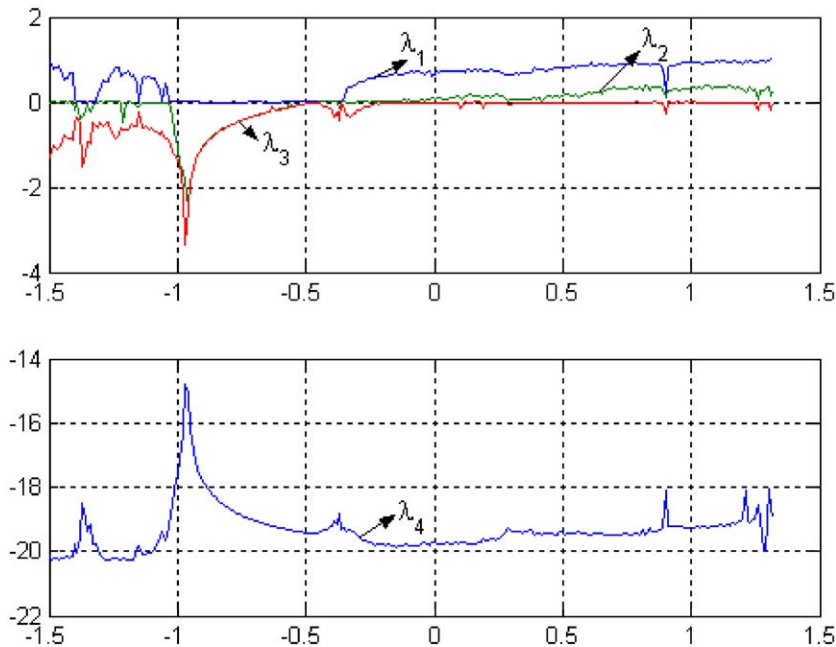

Fig. 1. Lyapunov exponents spectrum of hyperchaotic Lü system.

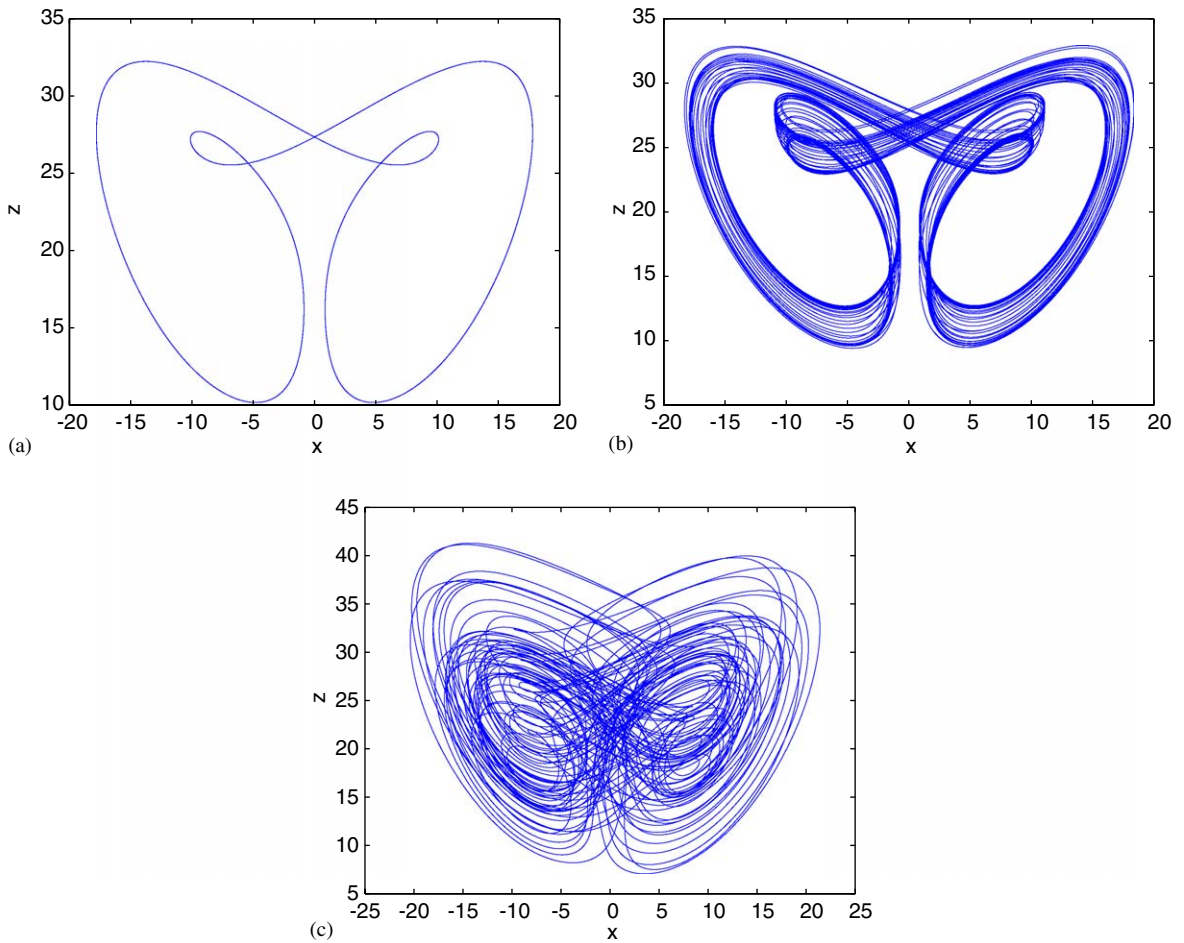

Fig. 2. Typical dynamical behaviors of system (2): (a) $d = -0.91$; (b) $d = -0.35$; (c) $d = 1$.

According to Fig. 4, it is very clear that the dynamical behaviors of system (2) evolve from chaotic state to periodic orbit, and then from periodic orbit to hyperchaotic state by going through a chaotic region with the increasing of control parameter d . In detailed, there are four different regions:

$$I_1 = [-1.5, -1.03], \quad I_2 = [-1.03, -0.46], \quad I_3 = (-0.46, -0.35], \quad I_4 = (-0.35, 1.3].$$

I_1, I_3 are chaotic regions and there is a periodic window in the region I_1 . I_2 is a periodic region and I_4 is a hyperchaotic region.

3.3. Poincaré mapping

Fig. 5 shows the Poincaré mapping of hyperchaotic Lü system in the $y-z$ plane, where $a = 36, b = 3, c = 20, d = 1.3$. From Fig. 5, system (2) has a self-similar structure and several sheets of the attractors are visualized. It is clear that some sheets are folded.

4. Circuit design and experimental observations

This section designs a novel circuit diagram to realize the hyperchaotic Lü system.

Fig. 6 shows the circuit diagram. Here, all resistors shown in Fig. 6 are adjustable resistors with high precision or potentiometers. Moreover, all original devices shown in Fig. 6 are operational amplifiers of type TL082 and operational multiplier of type AD633 with voltage supply ± 15 V.

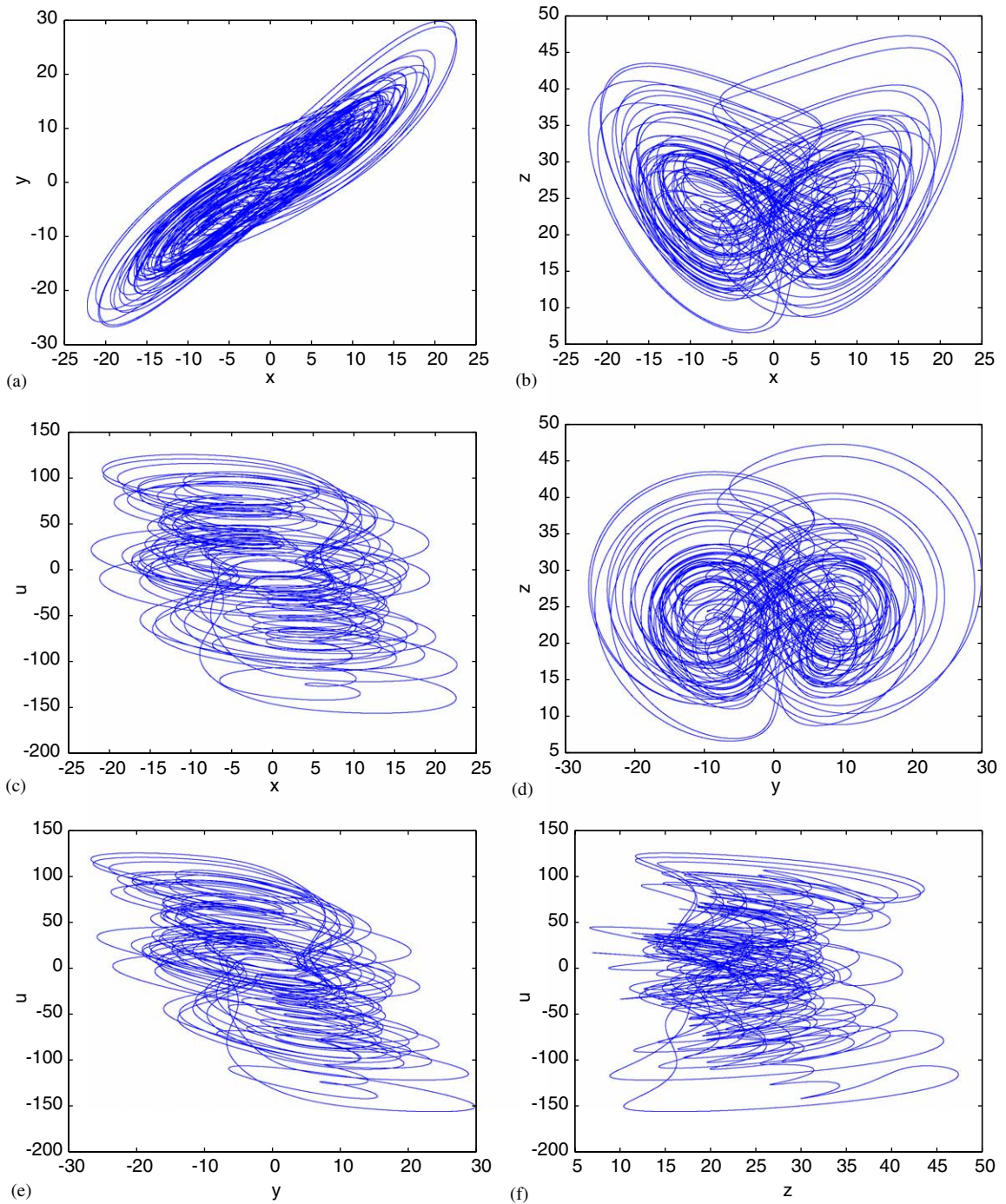

Fig. 3. Phase portraits of hyperchaotic Lü system (2): (a) $x - y$; (b) $x - z$; (c) $x - u$; (d) $y - z$; (e) $y - u$; (f) $z - u$.

The detailed switching means of switch K and resistor values are summarized as follows:

- (1) When switch K lies in position 2 and $R_{y1} = 5k, R_y = 19k, R_{u1} = 110k$, system (2) has a periodic orbit as shown in Fig. 7(a).

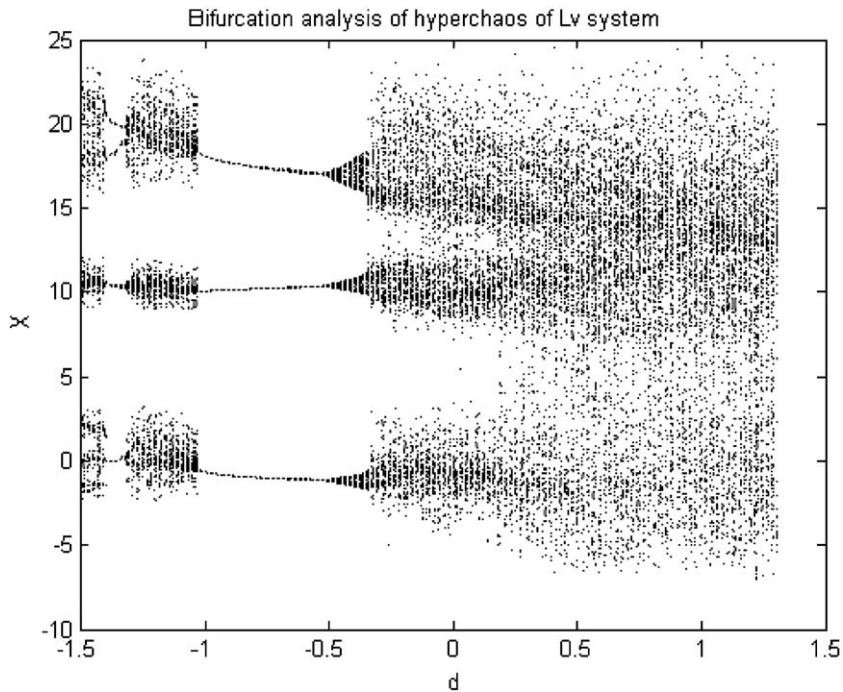

Fig. 4. Bifurcation diagram of hyperchaotic Lü system.

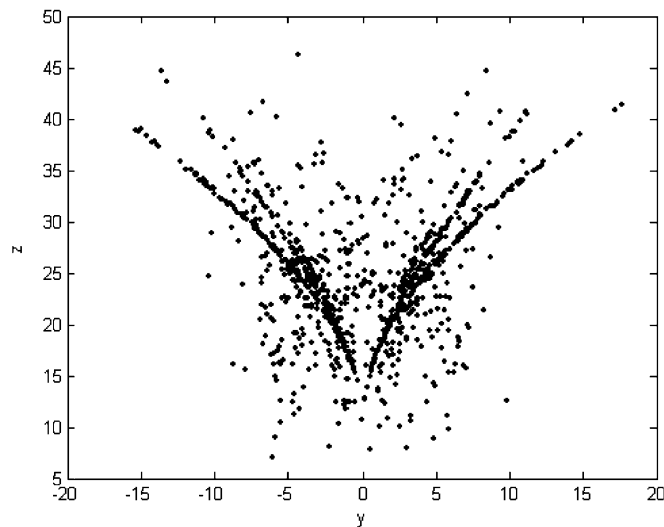

Fig. 5. Poincaré mapping of hyperchaotic Lü attractor.

- (2) When switch K lies in position 2 and $R_{y1} = 3.35k$, $R_y = 29.4k$, $R_{u1} = 285k$, system (2) has a chaotic attractor as shown in Fig. 7(b).
- (3) When switch K lies in position 1 and $R_{y1} = 5k$, $R_y = 26.1k$, $R_{u1} = 77k$, system (2) has a hyperchaotic attractor as shown in Fig. 8.

According to Figs. 2, 3, 7, 8, the experimental observations are well consistent with our numerical simulations. In detailed, Figs. 7(a) and (b) are the experimental observations of Figs. 2(a) and (b), respectively.

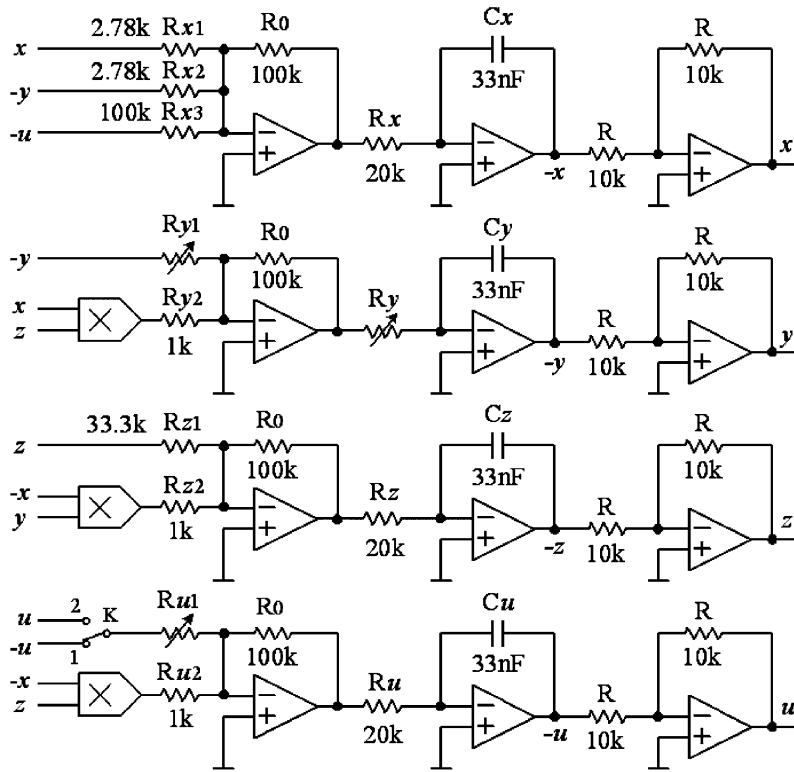

Fig. 6. Circuit diagram for realizing hyperchaotic Lü attractor.

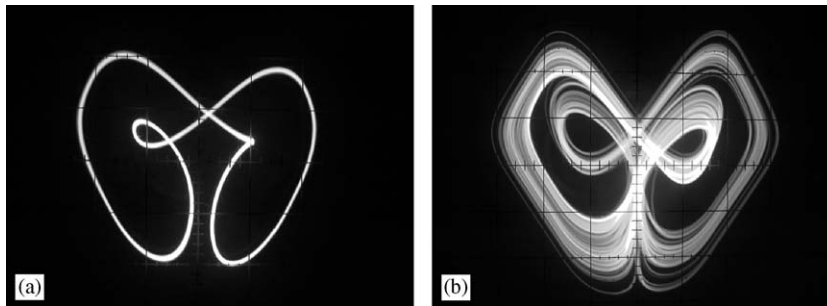

Fig. 7. Experimental observations of periodic orbit and chaotic state in $x-z$ plane: (a) $x = 1v/div, z = 0.5v/div$; (b) $x = 0.8v/div, z = 0.5v/div$.

Figs. 8(a)–(c) are the experimental observations of Figs. 3(a)–(c), respectively. Fig. 8(d) is the experimental observation of Fig. 3(e).

5. Conclusions and discussions

This paper has reported a new hyperchaotic system, called hyperchaotic Lü system. Some basic dynamical behaviors are explored by calculating its Lyapunov exponents spectrum, bifurcation diagram, and Poincaré mapping. Furthermore, the hyperchaotic behaviors are also verified by electronic circuits. Since the

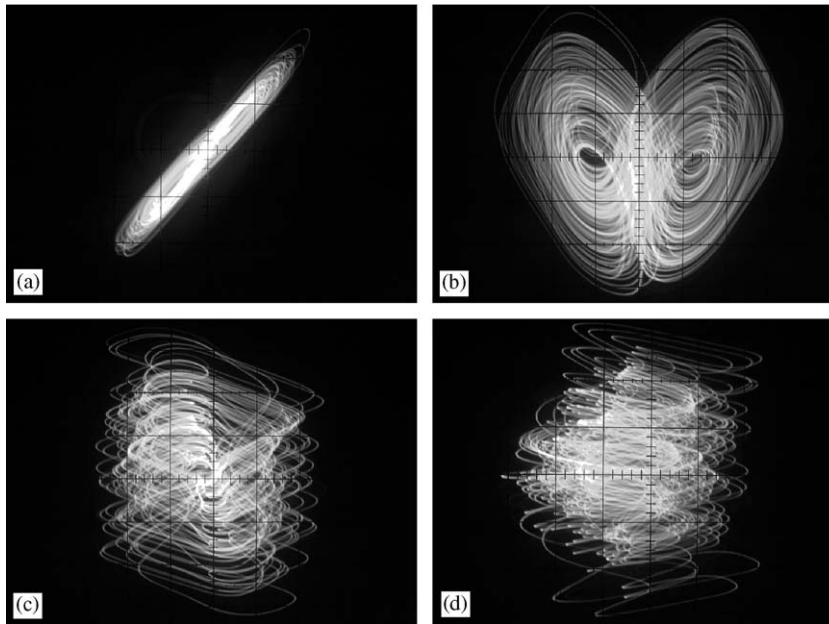

Fig. 8. Experimental observations of hyperchaotic Lü attractor in various projective planes: (a) $x = 1v/div, y = 1v/div$; (b) $x = 0.8v/div, z = 0.5v/div$; (c) $x = 1v/div, u = 3v/div$; (d) $z = 0.6v/div, u = 3v/div$.

hyperchaotic systems have more complex dynamical behaviors than the normal chaotic systems, it indicates that they will have broad applications in various chaos-based information systems.

Acknowledgements

This work was supported by the National Natural Science Foundation of China under Grants No. 60304017, No. 60574045, No. 60572073 and No. 20336040/B06, the National Key Basic Research and Development 973 Program of China under Grant No.2003CB415200, and the Scientific Research Startup Special Foundation on Excellent Ph.D. Thesis and Presidential Award of Chinese Academy of Sciences.

References

- [1] G. Chen, J. Lü, Dynamics of the Lorenz System Family: Analysis, Control and Synchronization, Science Press, Beijing, 2003 (in Chinese).
- [2] S. Li, G. Chen, X. Mou, IEEE Trans. Circuits Systems II 51 (2004) 665.
- [3] Y. Mao, G. Chen, Chaos-based image encryption, in: E. Bayro (Ed.), Handbook of Computational Geometry, Springer, Berlin, 2003.
- [4] J. Lü, G. Chen, Int. J. Bifurcat. Chaos 12 (2002) 659.
- [5] J. Lü, G. Chen, S. Zhang, Int. J. Bifurcat. Chaos 12 (2002) 1001.
- [6] J. Lü, G. Chen, D. Cheng, S. Čelikovský, Int. J. Bifurcat. Chaos 12 (2002) 2917.
- [7] J. Lü, G. Chen, D. Cheng, Int. J. Bifurcat. Chaos 14 (2004) 1507.
- [8] J. Lü, X. Yu, G. Chen, Physica A 334 (2004) 281.
- [9] S. Čelikovský, G. Chen, Int. J. Bifurcat. Chaos 12 (2002) 1789.
- [10] O.E. Rössler, Phys. Lett. A 57 (1976) 397.
- [11] A.L. Shilnikov, L.P. Shilnikov, D.V. Turaev, Int. J. Bifurcat. Chaos 3 (1993) 1123.
- [12] O.E. Rössler, Phys. Lett. A 71 (1979) 155.
- [13] C.Z. Ning, H. Haken, Phys. Rev. A 41 (1990) 3826.
- [14] T. Kapitaniak, L.O. Chua, Int. J. Bifurcat. Chaos 4 (1994) 477.
- [15] Y.X. Li, W.K.S. Tang, G. Chen, Int. J. Bifurcat. Chaos 15 (2005) in press.